

SMART MultiStylus with Tool Explorer (V2) technology



Overview

The SMART MultiStylus accessory kit is a multi-functional pen with a docking station that unlocks new capabilities on SMART Board® interactive displays with iQ 4, whether users are at the screen or moving freely around the room. With pen and air-mouse modes, customizable buttons, and integrated Tool Explorer™ (V2) support for cubes and stamps, it enables more interactive teaching, collaboration, and lesson presentation work flows.

Features

Supported functionality Pen mode
Air mouse mode

Buttons

- Programmable LED
- Up/Down
- Eraser

Stylus tip 4096 levels of pressure

Eraser Pressure-activated

Interactive experience

Pen mode functions Color selection | Highlighter | Pressure-sensitive ink | Up/Down buttons | Eraser | Open whiteboard

Air mouse mode functions Cursor | Highlighter | Screen shade | ESC key | Open digital assistant | Left/Right buttons

Tool Explorer™ function Optional cubes and stamps (V2)

Connectors and mounting

Docking station connector USB 2.0 Type-C Input

Docking station mount Magnetic, mounted on the display's frame

MultiStylus mount Magnetic, mounted on the docking station

Power

MultiStylus

Power source Ultra-capacitor

Auto-on Motion-activated

Usage time 10 hours (mode dependent)

Standby time 168 hours (in sleep mode; activates after 10 minutes of inactivity)

Charge time Quick charge: 1 minute for up to 60 minutes of usage time
Full charge: 6 minutes

Charge method Wireless charging using the docking station

Docking station

Power source 5V DC

Power consumption <4.5W

Storage and operating requirements

Operating temperature 41–95°F (5–35°C)

Storage temperature -40–76°F (-40–60°C)

Humidity 5–80% relative humidity, non-condensing

Included components	Qty
SMART MultiStylus	1
SMART Docking Station with Tool Explorer (V2) technology	1
USB 2.0 Type C to Type A, 3 m	1
Hardware set (1 screwdriver, 2 screws)	1
Illustrated installation instructions	1

SMART MultiStylus with Tool Explorer (V2) technology

Connectivity

Wired	USB-C to USB-A
Wireless operating range	>30 ft (9 m) (in an open area)

Tool integration

Software	iQ 4.7 or later SMART Product Drivers and Ink® SMART Notebook® 25 or later
Operating systems	Windows 11 MacOS 26
Compatible displays	SMART Board MX (V5) SMART Board MX (V5) Plus SMART Board QX (V2) Pro SMART Board RX
Accessories	Tool Explorer (V2) stamps and cubes

Certification and compliance

Regulatory models	SMART MultiStylus: PQR-3 SMART Docking station: CBQR-3
US / Canada	FCC ISED
EU / EEA / EFTA / UK	CE UKCA
Australia / New Zealand	RCM

Purchasing information

Order numbers

SMS-TE-IQ4	SMART MultiStylus with Tool Explorer (V2) technology, Accessory Kit, for displays with embedded iQ 4
-------------------	--

Optional accessories

TE-4CUBE-V2	Tool Explorer cubes
TE-4STAMP-V2	Tool Explorer stamps

SMART Warranty

Terms and conditions and warranty upgrade options vary by region. Visit smarttech.com/warranty or contact your reseller for information.

Installation, dimensions, and weights

Notes

- All dimensions ± 0.3 cm. All weights ± 5 g.

SMART MultiStylus

Dimensions

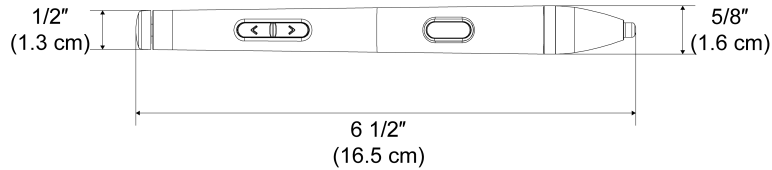

Weight

1.1 oz (31 g)

Shipping dimensions

8 1/4 x 3 5/8 x 1" (21 x 9.2 x 2.5 cm)

Shipping weight

3.2 oz (90 g)

SMART Docking Station

Dimensions

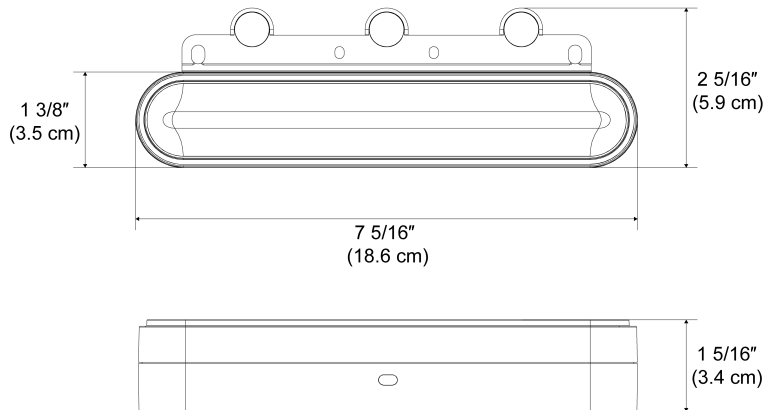

Weight

6.2 oz (175 g)

Shipping dimensions

9 7/8 x 5 1/2 x 3 1/4" (25 x 14 x 8.3 cm)

Shipping weight

11.5 oz (325 g)

smarttech.com
smarttech.com/contact

© 2026 SMART Technologies ULC. All rights reserved. SMART Board, smarttech, the SMART logo and all SMART taglines are trademarks or registered trademarks of SMART Technologies ULC in the U.S. and/or other countries. All third-party product and company names may be trademarks of their respective owners. This product and/or use thereof is covered by one or more of the following U.S. patents: www.smarttech.com/patents. Models and specifications may vary by region. Please contact your local representative for details. Contents are subject to change without notice. March 23, 2026.